

# HDT NORDIC CAROLINA COOLER

*Affordable, Portable and Versatile*



The Carolina Cooler is a unique, water-cooled, service-friendly package air conditioner that is designed for a variety of special purpose, heavy-duty air conditioning applications. This compact, rugged unit can be used with duct work or it can be supplied with a distribution plenum for on-the-spot air delivery.

## KEY FEATURES

- 18 gauge Galvalume frame cabinet. Lift and remove access panels on all sides of the condenser section eliminating the need for tools to remove.
- 10 fin per inch evaporator coil (others use up to 16 fins per inch which causes them to quickly build up with dirt and corrosion causing the system to malfunction)
- The drain pan is stainless steel
- The coils are sealed with an Epoxy corrosion-resistant coating. This not only protects the coil from leaks and poor efficiency but makes the coil cleaning much easier.
- A Copeland™ Scroll compressor (except 16K unit) is used for long life in the 24-7 schedules demanded by industrial applications
- The blower motor is totally enclosed and has a stainless steel shaft. Others use open motors, which allow dirt and corrosion in the windings.
- High and low pressure controls are provided. These controls save other costly components from damage.
- The condenser coil is cupra nickel for reliability
- A water regulating valve is incorporated inside the unit
- Water inlet, water outlet and drain connections are available on both sides of the unit
- Sight glass provided on front of unit
- On board controls provided includes military-rated selector switch and thermostat

## OPTIONAL FEATURES

- Electric heat
- Filter grille
- Caster kit
- Condensate tank and pump
- Remote thermostat
- Supply air plenum

# HDT NORDIC CAROLINA COOLER

Affordable, Portable and Versatile



SPECIFICATIONS	16K	22K	28K
<b>HDT Part Number</b>	2KR16CCW	2KR22CCW	2KR28CCW
<b>Refrigerant / Charge</b>	R407C	R407C	R407C
<b>Capacity</b>			
Cooling (nominal)	16,000 BTU / 4.69 kW	22,000 BTU / 6.5 kW	28,000 BTU / 8.21 kW
Heating	13,661 BTU / 4 kW	13,661 BTU / 4 kW	13,661 BTU / 4 kW
<b>Air Flow</b>	493 cfm / 838 m <sup>3</sup> h	638 cfm / 1084 m <sup>3</sup> h	621 cfm / 1055 m <sup>3</sup> h
<b>Dimensions (LxWxH)</b>	26.18" x 20.62" x 55.19" 66.5 x 52.4 x 140.2 cm	26.18" x 20.62" x 55.19" 66.5 x 52.4 x 140.2 cm	26.18" x 20.62" x 55.19" 66.5 x 52.4 x 140.2 cm
<b>Weight Net / Shipping</b>	235 lbs / 285 lbs 106.6 kg / 129.3 kg	223 lbs / 273 lbs 191.2 kg / 123.8 kg	259 lbs / 309 lbs 117.5 kg / 140.2 kg
<b>Electrical</b>	208–230V / 1 Phase / 60 Hz	208–230V / 1 Phase / 60 Hz	208–230V / 1 Phase / 60 Hz

SPECIFICATIONS	36K	48K	60K
<b>HDT Part Number</b>	2KR36CCW	2KR48CCW	2KR60CCW
<b>Refrigerant / Charge</b>	R407C	R407C	R407C
<b>Capacity</b>			
Cooling (nominal)	36,000 BTU / 10.55 kW	48,000 BTU / 14.07 kW	60,000 BTU / 17.58 kW
Heating	27,320 BTU / 8 kW	27,320 BTU / 8 kW	27,320 BTU / 8 kW
<b>Air Flow</b>	1150 cfm / 1954 m <sup>3</sup> h	1519 cfm / 2581 m <sup>3</sup> h	1519 cfm / 2581 m <sup>3</sup> h
<b>Dimensions (LxWxH)</b>	33" x 23.88" x 66" 83.8 x 60.7 x 167.6 cm	33" x 23.88" x 66" 83.8 x 60.7 x 167.6 cm	33" x 23.88" x 66" 83.8 x 60.7 x 167.6 cm
<b>Weight Net / Shipping</b>	393 lbs / 443 lbs 178.3 kg / 200.9 kg	402 lbs / 452 lbs 182.3 kg / 205 kg	419 lbs / 469 lbs 190 kg / 212.7 kg
<b>Electrical</b>	208–230V / 1 Phase / 60 Hz 460V / 3 Phase / 60 Hz 460V / 3 Phase / 60 Hz	08–230V / 1 Phase / 60 Hz 208–230V / 3 Phase / 60 Hz 460V / 3 Phase / 60 Hz	208–230V / 1 Phase / 60 Hz 208–230V / 3 Phase / 60 Hz 460V / 3 Phase / 60 Hz

Additional specifications available, please contact us.

Products, product specifications and data are subject to change without notice to improve reliability, function, and/or design. Please contact Customer Service at 800.969.8527 for the most up-to-date product information.

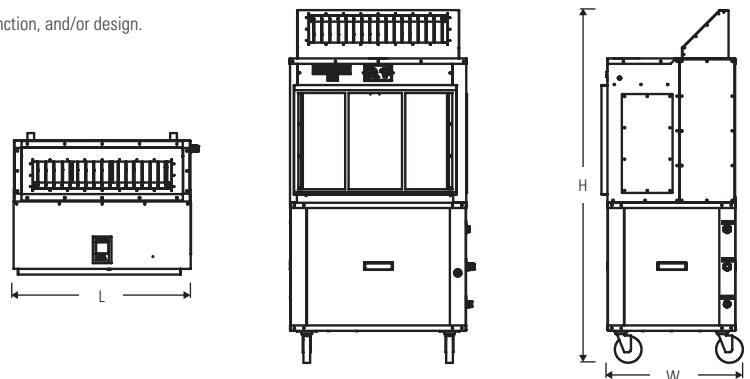

## HDT Expeditionary Systems, Inc.

30500 Aurora Road, Suite 100, Solon, OH 44139 USA  
P 800.969.8527 / 216.HDT.6111 / sales@hdtglobal.com

NON-EXPORT CONTROLLED INFORMATION

Revision 3 05-24 01-05-01-0095